

# C15C C15

**15/18/20sC**

IC-CUSHION      LPG  
3000 / 3500 / 4000 lbs.  
(1500 / 1800 / 2000 kg)

**15/18/20s**

IC-PNEUMATIC      LPG/DIESEL  
3000 / 3500 / 4000 lbs.  
(1500 / 1800 / 2000 kg)

**GEN 2**



**CLARK**®

**THE FORKLIFT**



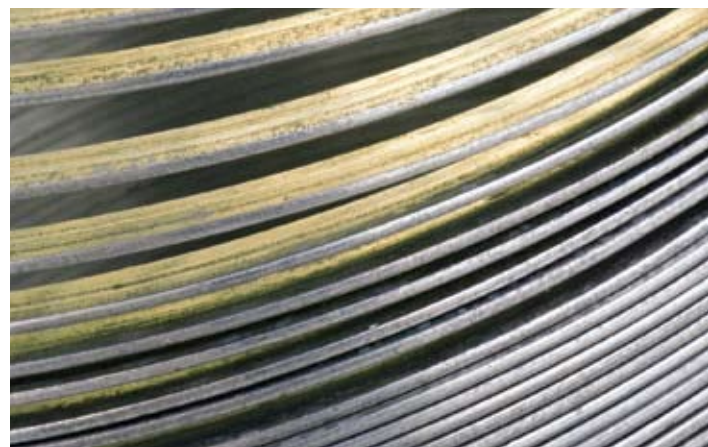

## Highly Maneuverable, Easily Serviceable, Broadly Flexible, Extremely Dependable

The Gen2 C15-Series proudly adds to CLARK's unique history of building the best forklifts with evolutionary steps in **ergonomics, power, safety, durability** and **performance**. These narrow-width models, designed for distribution, manufacturing and warehousing of all types, are suited for the toughest applications.



# 98%

The two-stage engine air filter removes **Ninety-Eight Percent** of incoming dust before it enters the filter media.

- Nested upright rails provide positive rail interlock and a narrow “column” to **maximize the vision window**. The overhead guard safety bars run parallel to the operator’s line of sight resulting in a **clear, unobstructed view**.

Maximum Visibility + Minimum Fatigue =  
**Ultimate Safety & Product Integrity**







- With four turns lock-to-lock the **hydrostatic power steering** provides the operator with excellent maneuverability and ease of control.

- Low, open foot steps with **traction plates** make entry/exit quick, easy, and safe.



## Rugged Durability, High Performance, Extreme Environments, Demanding Applications

The GEN2 series is designed to tackle any task placed in its path. The open-core, plate-fin radiator provides **maximum cooling of the engine, transmission and axle in the harshest environments** and the most demanding applications.



# 10%

The Mitsubishi LPG engine produces only 10% of the allowable carbon monoxide by EPA emission standards.

- With available options including **full featured cab**, **various tire configurations**, **LED light technology**, **clean air package**, **custom tilts** and **rear work lights** (just to name a few) there is practically no application whose needs can't be met.

Smooth Control + Easy Operation =  
**Operator Confidence & Optimum Comfort**



# C15 STANDARD FEATURES & BENEFITS



## PARKING BRAKE

- Foot-applied brake can be released by hand or foot.
- Transmission disengages when parking brake is set preventing driving against brakes.
- Horn will sound if brake is not set after 3 seconds from when engine is shut off.

## HYDRAULIC SYSTEM

- **Maximum Horsepower**
  - Uses a load-sensing flow control valve for steering to reduce horsepower loss and heat buildup.
- **Optimum Performance Of Attachments**
  - The main hydraulic valve incorporates adjustable flow controls for tilt and auxiliary functions.
- **Sectional Design**
  - Allows for easy addition of extra functions and simplifies service.
- **Upright Mounted Load Lowering Valve**
  - Controlled lowering independent of engine speed.

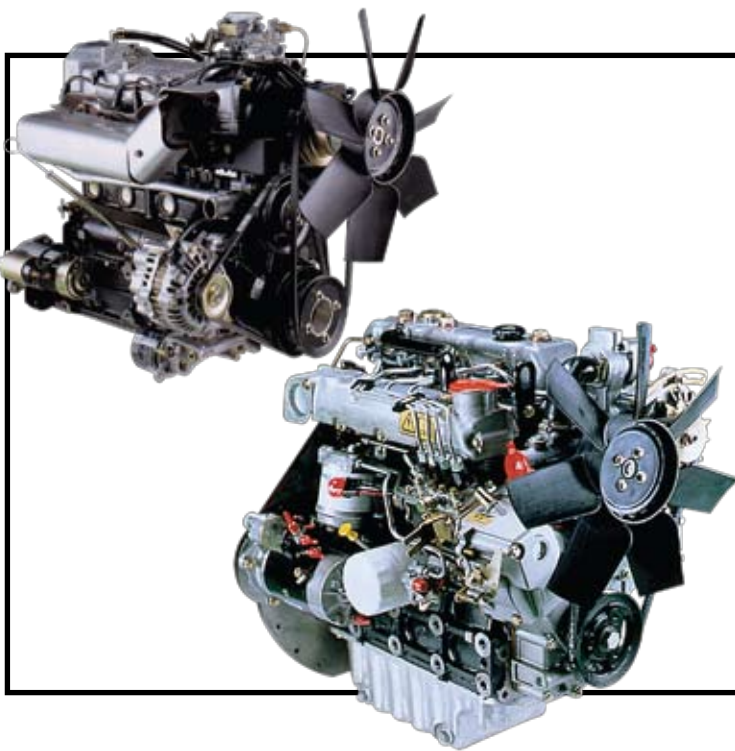

## THE POWER BEHIND THE PUNCH

- **Field-Proven Mitsubishi 4G63 LPG Engine**
  - Provides smooth, quiet operation.
  - Only produces 10% of the allowable carbon-monoxide by today's EPA low-emission standards.
- **World Recognized Yanmar 4TNV88 Diesel Engine**
  - Excellent fuel economy.
  - Vertical exhaust comes standard.
- **Keeping Uptime To A Maximum**
  - Spin on transmission and engine oil filters are used for easy replacement.
  - Fluid levels can be checked from engine compartment.
- **EPA Compliant**
  - Engines meet reduced emission and smoke levels.

## Available Equipment

- Mirrors
- Sideshifters
- Strobe lights
- Backup alarm
- Rear work light
- Auxiliary valves
- Turn signal lights
- Hose adaptations
- Combination stop/tail/backup lights
- Hydraulic control options
- Bottler's tilt
- Tire options
- Travel speed limit
- Convenience console
- Air cleaner safety element
- Pre-cleaner, overhead guard mounted
- U.L. Type LPS construction
- Suspension seat, vinyl and cloth
- Reduced height overhead guard
- Swing-down LPG tank bracket
- Seat actuated engine shutdown

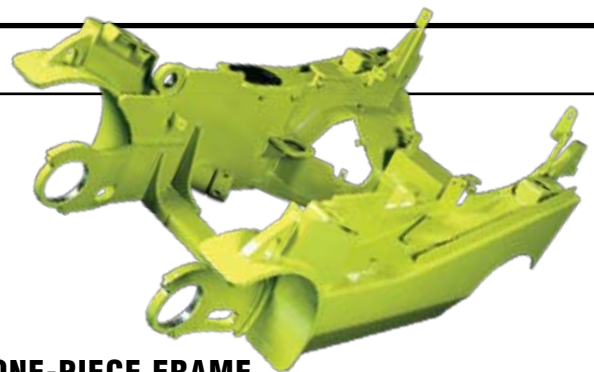

## ONE-PIECE FRAME

- Heavy duty, welded, and formed steel plate design protects from impact damage and extends the life of the truck.
- An integral hydraulic sump, with remote breather provides cooling for hydraulics in tough applications.





## STEERING AXLE

### ■ Rugged Design

- Linkage pivot pins are “double shear” design to withstand impact without loosening or breaking.

### ■ Simple Axle Design

- Double-ended cylinder provides steering force.



## RUGGED UPRIGHT AND CARRIAGE

### ■ Maximum Visibility

- Nested I-Channel allows space for cylinders, hoses and chains.

### ■ Hydraulic Cushioning Valves

- Silent Staging Reduces Shock & Vibration.

### ■ Shimmable, Sealed & Canted Load Rollers

- Carriage has 6 load rollers.
- Maximize Load Distribution & Reduce Free Play.



## DASH DISPLAY

### ■ Microprocessor

- Monitors the condition of truck systems as well as controlling their functions.
- Controls neutral starting and prevents cranking while the engine is running.

### ■ Gauges

- Engine coolant temperature.
- Fuel level for Diesel.

### ■ LCD Display

- Hourmeter and maintenance interval are displayed on the LCD screen.

### ■ LED Lights Indicate

- High transmission temperature • Low engine oil pressure
- Alternator charge • Fuel system malfunction
- Park brake applied • Maintenance required • Seat belt

### ■ Push Switches

- Headlight and optional worklights are controlled with push switches.



## OPERATOR COMPARTMENT

### ■ Optional Fully Adjustable, Full Suspension Seat

- 2.4” Vertical Travel • 20° Backrest Adjustment Range
- 6” fore / aft adjustment • Contoured for support
- Non-Cinching, Retractable Seat Belt

### ■ Thick Molded Floor Mat

- Reduces vibration and noise level.
- Improves operator comfort.

### ■ Minimal Arm Fatigue

- Electronic directional controls enable true fingertip operation.

### ■ Tilt Steering Column

- Adjusts to Suit Operator & Easier Entry/Exit.

# GENERAL DATA & STANDARD DIMENSIONS

## Upright Table

Maximum <sup>1</sup> Fork Height in mm		Overall Height Lowered in mm		Free Lift <sup>3</sup> w/o LBR in mm		Standard <sup>2</sup> Tilt Spec B°/F°
<b>C15/18/20sC Standard</b>						
89	2265	67	1693	4.3	110	8/8
100	2545	72	1833	4.3	110	8/8
110	2795	77	1958	4.3	110	8/8
121	3085	83	2103	4.3	110	8/8
• 129	3285	87	2203	4.3	110	8/8
143	3640	94	2380	4.3	110	8/8
160	4070	104	2653	4.3	110	5/6
172	4365	112	2853	4.3	110	5/6
183	4655	120	3048	4.3	110	5/6
203	5145	133	3378	4.3	110	4/3
<b>C15/18/20sC Triple Stage</b>						
156	3970	72	1833	49	1201	5/6
171	4345	77	1958	54	1326	5/6
• 188	4780	83	2103	59	1471	5/6
204	5185	89	2253	65	1621	4/3
213	5400	92	2343	69	1711	4/3
219	5565	95	2413	72	1781	4/3
225	5720	98	2478	74	1846	4/3
237	6015	102	2603	79	1971	4/3
255	6470	110	2793	87	2161	2/0
279	7075	120	3048	97	2416	2/0
<b>C15/18/20sC Hi-Lo</b>						
115	2925	77	1955	54	1323	8/8
• 127	3215	83	2115	60	1483	8/8
138	3515	89	2255	65	1623	8/8
145	3695	95	2405	71	1773	8/8
150	3810	98	2480	74	1848	8/8

\* Indicates Common Preferred Spec

<sup>1</sup> For overall height raised with load backrest, add 48 in. (1220 mm) to maximum fork height.

<sup>2</sup> Standard tilt shown. Contact Clark representative for information on optional tilt.

<sup>3</sup> Freelif dimensions shown are without load backrest.

Other uprights available, contact a Clark representative.

## Notes

Production engines and driveline components may vary in output and/or efficiency by ±5%. The performance shown represents nominal values which may be obtained under typical operating conditions of a machine.

## ANSI/ITSDF and Insurance Classification

Standard truck meets all applicable mandatory requirements of Part III-ANSI/ITSDF B56.1 Safety Standard for Powered Industrial Trucks and Underwriters Laboratories requirements as to fire hazard only for D and LP classifications. For further information contact a Clark representative.

Users should be aware of, and adhere to, applicable codes and regulations regarding operator training, use, operation and maintenance of powered industrial trucks, including:

- ANSI/ITSDF B56.1
- NFPA 505, fire safety standard for powered industrial trucks - type designations, areas of use, maintenance and operation.
- Occupational Safety and Health Administration (OSHA) regulations that may apply.

Contact your authorized CLARK forklift truck dealer for further information including operator training programs and auxiliary visual and audible warning systems, fire extinguishers, etc., as available for specific user applications and requirements.

Specifications, equipment, technical data, photos and illustrations are based on information at time of printing and are subject to change without notice. Some products may be shown with optional equipment.

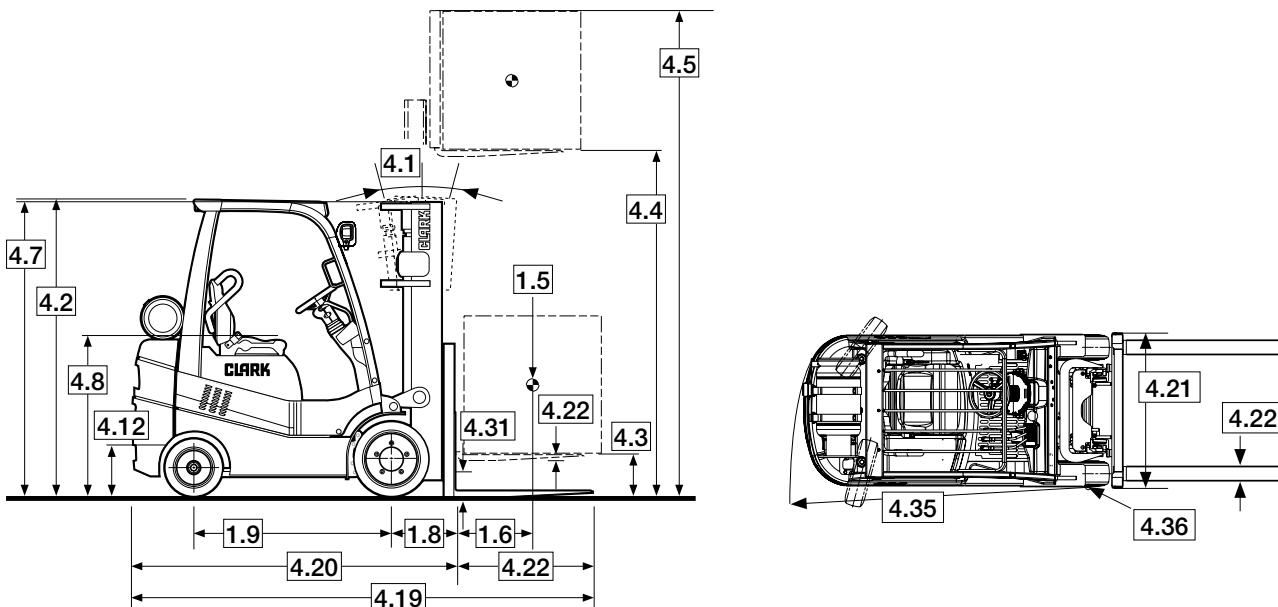

For corresponding data see Specification Chart



## Upright Table

Maximum <sup>1</sup> Fork Height in mm		Overall Height Lowered in mm		Free Lift <sup>3</sup> w/o LBR in mm		Standard <sup>2</sup> Tilt Spec B°/F°
<b>C15/18/20s Standard</b>						
89	2265	68	1730	4.3	110	8/8
100	2545	74	1870	4.3	110	8/8
110	2795	79	1995	4.3	110	8/8
121	3085	84	2140	4.3	110	8/8
• 129	3285	88	2240	4.3	110	8/8
143	3640	95	2417	4.3	110	8/8
160	4070	106	2690	4.3	110	5/6
172	4365	114	2890	4.3	110	5/6
183	4655	121	3085	4.3	110	5/6
203	5145	134	3415	4.3	110	5/3
<b>C15/18/20s Triple Stage</b>						
156	3970	74	1870	49	1238	5/6
171	4345	79	1995	54	1363	5/6
• 188	4780	84	2140	59	1508	5/6
204	5185	90	2290	65	1658	5/3
213	5400	94	2380	69	1748	5/3
219	5565	96	2450	72	1818	5/3
225	5720	99	2515	74	1883	5/3
237	6015	104	2640	79	2008	5/3
255	6470	111	2830	87	2198	3/0
279	7075	121	3085	97	2453	3/0
<b>C15/18/20s Hi-Lo</b>						
115	2925	79	2005	55	1389	8/8
• 127	3215	85	2165	61	1549	8/8
138	3515	91	2305	66	1689	8/8
145	3695	97	2455	72	1839	8/8
150	3810	100	2530	75	1914	8/8

\* Indicates Common Preferred Spec

<sup>1</sup> For overall height raised with load backrest, add 48 in. (1220 mm) to maximum fork height.

<sup>2</sup> Standard tilt shown. Contact Clark representative for information on optional tilt.

<sup>3</sup> Freelif dimensions shown are without load backrest.

Other uprights available, contact a Clark representative.

## Notes

Production engines and driveline components may vary in output and/or efficiency by ±5%. The performance shown represents nominal values which may be obtained under typical operating conditions of a machine.

### ANSI/ITSDF and Insurance Classification

Standard truck meets all applicable mandatory requirements of Part III-ANSI/ITSDF B56.1 Safety Standard for Powered Industrial Trucks and Underwriters Laboratories requirements as to fire hazard only for D and LP classifications. For further information contact a Clark representative.

Users should be aware of, and adhere to, applicable codes and regulations regarding operator training, use, operation and maintenance of powered industrial trucks, including:

- ANSI/ITSDF B56.1
- NFPA 505, fire safety standard for powered industrial trucks - type designations, areas of use, maintenance and operation.
- Occupational Safety and Health Administration (OSHA) regulations that may apply.

Contact your authorized CLARK forklift truck dealer for further information including operator training programs and auxiliary visual and audible warning systems, fire extinguishers, etc., as available for specific user applications and requirements.

Specifications, equipment, technical data, photos and illustrations are based on information at time of printing and are subject to change without notice. Some products may be shown with optional equipment.

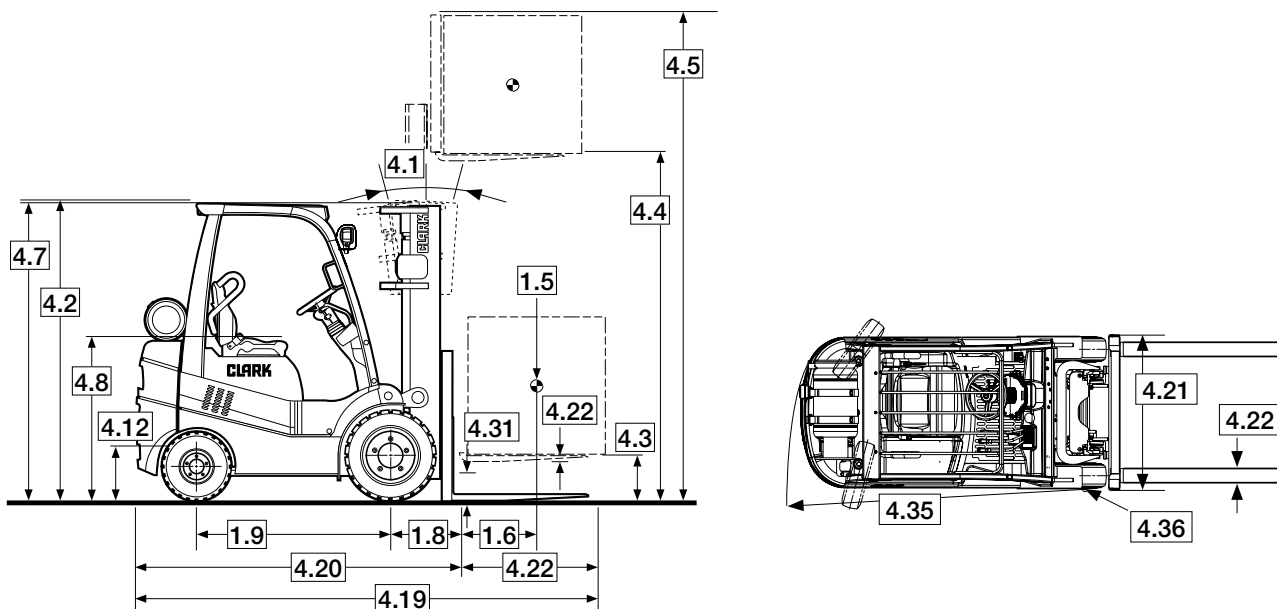

For corresponding data see Specification Chart

# STANDARD SPECIFICATIONS

# C15/18/20sC

Specifications	1.1	Manufacturer		Clark	Clark
	1.2	Manufacturer's Designation		C15CL	C18CL
	1.3	Drive unit Diesel, L.P. Gas		LPG	LPG
	1.4	Operator type stand on / driver seated		Rider-Seated	Rider-Seated
	1.5	Load capacity / rated load	lbs(kg)	3000 (1500)	3500 (1800)
	1.6	Load center distance	in(mm)	24 (500)	24 (500)
	1.8	Load center distance, center of drive axle to fork face	in(mm)	STD 14.7 (375)   TSU 14.9 (378)	STD 14.7 (375)   TSU 14.9 (378)
	1.9	Wheelbase	in(mm)	48.0 (1220)	48.0 (1220)
	Weight	2.1	Service weight	lbs(kg)	STD 6056 (2746)   TSU 6424 (2913)
2.2		Axle loading, loaded front / rear	lbs(kg)	STD 7985/1071 (3740/507)   TSU 8438/986 (3847/463)	STD 8733/1296 (4210/552)   TSU 9188/1209 (4053/473)
2.3		Axle loading, unloaded front / rear	lbs(kg)	STD 2566/3490 (1164/1583)   TSU 3007/3417 (1364/1550)	STD 2411/4118 (1094/1868)   TSU 2852/4045 (1294/1835)
Tires	3.1	Tire type, P = pneumatic, SE = solid pneu, C = cushion		Cushion	Cushion
	3.2	Tire size, front	in	18x6x12.125	18x6x12.125
	3.3	Tire size, rear	in	14x4.5x8	14x4.5x8
	3.5	Wheels, number front / rear (x = drive wheels)		2X/2	2X/2
	3.6	Tread, front	in(mm)	31.1 (789)	31.1 (789)
	3.7	Tread, rear		32.4 (822)	32.4 (822)
	Dimensions	4.1	Tilt of upright / fork carriage, back / forward, a / b	degrees	STD 8/8   TSU 5/6
4.2		Height, upright lowered	in(mm)	STD 86.7 (2203)   TSU 82.8 (2103)	STD 86.7 (2203)   TSU 82.8 (2103)
4.3		Freelift	in(mm)	STD 4.3 (110)   TSU 57.9 (1471)	STD 4.3 (110)   TSU 57.9 (1471)
4.4		Lift height	in(mm)	STD 129 (3285)   TSU 188 (4780)	STD 129 (3285)   TSU 188 (4780)
4.5		Height, upright extended	in(mm)	STD 177.0 (4496)   TSU 236.0 (5994)	STD 177.0 (4496)   TSU 236.0 (5994)
4.7		Height overhead guard	in(mm)	81.1 (2060)	81.1 (2060)
4.8		Seat height		40.2 (1021)	40.2 (1021)
4.12		Coupling height	in(mm)	10.25 (260)	10.25 (260)
4.19		Overall length	in(mm)	STD 122.0 (3099)   TSU 122.2 (3104)	STD 123.6 (3139)   TSU 123.8 (3145)
4.20		Length to face of forks	in(mm)	STD 80.0 (2033)   TSU 80.2 (2036)	STD 81.6 (2075)   TSU 81.8 (2078)
4.21		Width	in(mm)	37.0 (940)	37.0 (940)
4.22		Fork dimensions	in(mm)	1.5x4x42 (40x100x1070)	1.5x4x42 (40x100x1070)
4.23		Fork carriage		Hook Type	Hook Type
4.24		Fork carriage width	in(mm)	33.0 (838)	33.0 (838)
4.31		Ground clearance minimum, loaded	in(mm)	3.2 (82)	3.2 (82)
4.32		Ground clearance center of wheelbase	in(mm)	5.0 (127)	5.0 (127)
4.34		Right Angle Stack (add load length and clearance)	in(mm)	STD 85.2 (2167)   TSU 85.4 (2170)	STD 87.2 (2215)   TSU 87.4 (2218)
4.35	Outside turning radius	in(mm)	70.5 (1792)	72.5 (1840)	
4.36	Inside turning radius	in(mm)	3.5 (90)	3.3 (83)	
Performance	5.1	Travel speed loaded / unloaded	mph(kph)	10.5/10.6 (16.9/17)	10.5/10.6 (16.9/17)
	5.2	Lift speed loaded / unloaded	fpm(ms)	STD 112/120 (0.57/0.61)   TSU 106/114 (0.54/0.58)	STD 110/120 (0.56/0.61)   TSU 104/114 (0.53/0.58)
	5.3	Lowering speed loaded / unloaded	fpm(ms)	STD 88/82 (0.45/0.42)   TSU 84/79 (0.43/0.40)	STD 88/82 (0.45/0.42)   TSU 84/79 (0.43/0.40)
	5.6	Max. drawbar pull loaded	lbs(N)	3913/1807 (17407/8041)	3785/1763 (16838/7845)
	5.8	Max. gradeability loaded / unloaded	%	46.0/26.7	38.6/24.1
	5.10	Service brake		Drum	Drum
Drive Line	7.1	Manufacturer / Type		Mitsubishi 4G63	Mitsubishi 4G63
	7.2	Rated output per SAE J1349	HP/kW @ rpm	39.5 (29) @ 2100	39.5 (29) @ 2100
	7.3	Rated speed	rpm	2650	2650
	7.4	No. of cylinders / displacement	cu. in.-Liters	4 / 122 (2.0)	4 / 122 (2.0)
	8.2	Operating pressure for attachments	psi/bar	2030 (140)	2030 (140)
	8.4	Sound level, driver's ear	dB(A)	80	80



Clark	Clark	Clark	Clark
C20sCL	C15L	C18L	C20sL
LPG	LPG	LPG	LPG
Rider-Seated	Rider-Seated	Rider-Seated	Rider-Seated
4000 (2000)	3000 (1500)	3500 (1800)	4000 (2000)
24 (500)	24 (500)	24 (500)	24 (500)
STD 14.7 (375)   TSU14.9 (378)	STD 15.4 (392)   TSU 15.5 (395)	STD 15.4 (392)   TSU 15.5 (395)	STD 15.4 (392)   TSU 15.5 (395)
48.0 (1220)	55.1 (1400)	55.1 (1400)	55.1 (1400)
STD 6842 (3104)   TSU 7210 (3271)	STD 6140 (2785)   TSU 6507 (2952)	STD 6633 (3009)   TSU 7001 (3176)	STD 6957 (3156)   TSU 7325 (3323)
STD 9526/1316 (4507/598)   TSU 9984/1226 (4172/496)	STD 7960/1180 (3733/552)   TSU 8397/1110 (3933/519)	STD 8690/1443 (4166/643)   TSU 9128/1373 (4100/573)	STD 9458/1499 (4449/707)   TSU 9890/1435 (4210/610)
STD 2301/4541 (1044/2060)   TSU 2742/4468 (1244/2027)	STD 2815/3325 (1277/1508)   TSU 3247/3260 (1473/1479)	STD 2687/3946 (1219/3946)   TSU 3119/3882 (1415/1761)	STD 2590/4367 (1175/1981)   TSU 3022/4303 (1371/1952)
Cushion	Pneumatic	Pneumatic	Pneumatic
18x6x12.125	6.50x10-12PR	6.50x10-12PR	6.50x10-12PR
14x4.5x8	5.00x8-10PR	5.00x8-10PR	5.00x8-10PR
2X/2	2X/2	2X/2	2X/2
31.1 (789)	35.0 (890)	35.0 (890)	35.0 (890)
32.4 (822)	35.0 (890)	35.0 (890)	35.0 (890)
STD 8/8   TDU 5/6	STD 8/8   TSU 5/6	STD 8/8   TSU 5/6	STD 8/8   TSU 5/6
STD 86.7 (2203)   TSU 82.8 (2103)	STD 88.1 (2240)   TSU 84.2 (2140)	STD 88.1 (2240)   TSU 84.2 (2140)	STD 88.1 (2240)   TSU 84.2 (2140)
STD 4.3 (110)   TSU 57.9 (1471)	STD 4.3 (110)   TSU 59.3 (1508)	STD 4.3 (110)   TSU 59.3 (1508)	STD 4.3 (110)   TSU 59.3 (1508)
STD 129 (3285)   TSU 188 (4780)	STD 129 (3285)   TSU 188 (4780)	STD 129 (3285)   TSU 188 (4780)	STD 129 (3285)   TSU 188 (4780)
STD 177.0 (4496)   TSU 236.0 (5994)	STD 177 (4496)   TSU 236 (5994)	STD 177 (4496)   TSU 236 (5994)	STD 177 (4496)   TSU 236 (5994)
81.1 (2060)	83.5 (2120)	83.5 (2120)	83.5 (2120)
40.2 (1021)	42.2 (1072)	42.2 (1072)	42.2 (1072)
10.25 (260)	11.5 (292)	11.5 (292)	11.5 (292)
STD 124.7 (3167)   TSU 124.9 (3173)	STD 128.4 (3261)   TSU 128.5	STD 130.2 (3307)   TSU 130.3 (3310)	STD 131.9 (3350)   TSU 132.0 (3353)
STD 82.7 (2103)   TSU 82.9 (2106)	STD 86.4 (2196)   TSU 86.5 (2199)	STD 88.2 (2241)   TSU 88.3 (2244)	STD 89.9 (2283)   TSU 90.0 (2286)
37.0 (940)	42.1 (1070)	42.1 (1070)	42.1 (1070)
1.5x4x42 (40x100x1070)	1.5x4x42 (40x100x1070)	1.5x4x42 (40x100x1070)	1.5x4x42 (40x100x1070)
Hook Type	Hook Type	Hook Type	Hook Type
33.0 (838)	41.0 (1042)	41.0 (1042)	41.0 (1042)
3.2 (82)	4.72 (120)	4.72 (120)	4.72 (120)
5.0 (127)	4.8 (124)	4.8 (124)	4.8 (124)
STD 88.2 (2241)   TSU 88.4 (2244)	STD 97.0 (2465)   TSU 97.1 (2468)	STD 98.9 (2513)   TSU 99.0 (2516)	STD 100.2 (2546)   TSU 100.3 (2549)
73.5 (1866)	81.6 (2073)	83.5 (2121)	84.8 (2154)
3.3 (83)	11.22 (285)	11.22 (285)	11.22 (285)
10.5/10.6 (16.9/17)	11.2 / 11.4 (18 / 18.4)	11.1 / 11.4 (17.9 / 18.4)	11.1 / 11.4 (17.9 / 18.4)
STD 104/120 (0.54/0.61)   TSU 100/114 (0.51/0.58)	STD 112/120 (0.57/0.61)   TSU 106/114 (0.54/0.58)	STD 110/120 (0.56/0.61)   TSU 104/114 (0.53/0.58)	STD 106/120 (0.54/0.61)   TSU 100/114 (0.51/0.58)
STD 88/82 (0.45/0.42)   TSU 84/79 (0.43/0.40)	STD 88/82 (0.45/0.42)   TSU 84/79 (0.43/0.40)	STD 88/82 (0.45/0.42)   TSU 84/79 (0.43/0.40)	STD 88/82 (0.45/0.42)   TSU 84/79 (0.43/0.40)
3776/1730 (16799/7698)	3908/2425 (17387/10787)	3924/2425 (17456/10787)	3935/2204 (17505/9807)
35.6/22.6	45.6 / 21.1	39.4 / 19.8	37.0 / 17.1
Drum	Drum	Drum	Drum
Mitsubishi 4G63	Mitsubishi 4G63	Mitsubishi 4G63	Mitsubishi 4G63
39.5 (29) @ 2100	39.5 (29) @ 2100	39.5 (29) @ 2100	39.5 (29) @ 2100
2650	2650	2650	2650
4 / 122 (2.0)	4 / 122 (2.0)	4 / 122 (2.0)	4 / 122 (2.0)
2030 (140)	2030 (140)	2030 (140)	2030 (140)
80	79	79	79

# C15/18/20s

Clark	Clark	Clark
C15D	C18D	C20sD
Diesel	Diesel	Diesel
Rider-Seated	Rider-Seated	Rider-Seated
3000 (1500)	3500 (1800)	4000 (2000)
24 (500)	24 (500)	24 (500)
STD 15.4 (392)   TSU 15.5 (395)	STD 15.4 (392)   TSU 15.5 (395)	STD 15.4 (392)   TSU 15.5 (395)
55.1 (1400)	55.1 (1400)	55.1 (1400)
STD 6140 (2785)   TSU 6507 (2952)	STD 6633 (3009)   TSU 7001 (3176)	STD 6957 (3156)   TSU 7325 (3323)
STD 7960/1180 (3733/552)   TSU 8397/1110 (3933/519)	STD 8690/1443 (4166/643)   TSU 9128/1373 (4100/573)	STD 9458/1499 (4449/707)   TSU 9890/1435 (4210/610)
STD 2815/3325 (1277/1508)   TSU 3247/3260 (1473/1479)	STD 2687/3946 (1219/3946)   TSU 3119/3882 (1415/1761)	STD 2590/4367 (1175/1981)   TSU 3022/4303 (1371/1952)
Pneumatic	Pneumatic	Pneumatic
6.50x10-12PR	6.50x10-12PR	6.50x10-12PR
5.00x8-10PR	5.00x8-10PR	5.00x8-10PR
2X/2	2X/2	2X/2
35.0 (890)	35.0 (890)	35.0 (890)
35.0 (890)	35.0 (890)	35.0 (890)
STD 8/8   TSU 5/6	STD 8/8   TSU 5/6	STD 8/8   TSU 5/6
STD 88.1 (2240)   TSU 84.2 (2140)	STD 88.1 (2240)   TSU 84.2 (2140)	STD 88.1 (2240)   TSU 84.2 (2140)
STD 4.3 (110)   TSU 59.3 (1508)	STD 4.3 (110)   TSU 59.3 (1508)	STD 4.3 (110)   TSU 59.3 (1508)
STD 129 (3285)   TSU 188 (4780)	STD 129 (3285)   TSU 188 (4780)	STD 129 (3285)   TSU 188 (4780)
STD 177 (4496)   TSU 236 (5994)	STD 177 (4496)   TSU 236 (5994)	STD 177 (4496)   TSU 236 (5994)
83.5 (2120)	83.5 (2120)	83.5 (2120)
42.2 (1072)	42.2 (1072)	42.2 (1072)
11.5 (292)	11.5 (292)	11.5 (292)
STD 128.4 (3261)   TSU 128.5	STD 130.2 (3307)   TSU 130.3 (3310)	STD 131.9 (3350)   TSU 132.0 (3353)
STD 86.4 (2196)   TSU 86.5 (2199)	STD 88.2 (2241)   TSU 88.3 (2244)	STD 89.9 (2283)   TSU 90.0 (2286)
42.1 (1070)	42.1 (1070)	42.1 (1070)
1.5x4x42 (40x100x1070)	1.5x4x42 (40x100x1070)	1.5x4x42 (40x100x1070)
Hook Type	Hook Type	Hook Type
41.0 (1042)	41.0 (1042)	41.0 (1042)
4.72 (120)	4.72 (120)	4.72 (120)
4.8 (124)	4.8 (124)	4.8 (124)
STD 97.0 (2465)   TSU 97.1 (2468)	STD 98.9 (2513)   TSU 99.0 (2516)	STD 100.2 (2546)   TSU 100.3 (2549)
81.6 (2073)	83.5 (2121)	84.8 (2154)
11.22 (285)	11.22 (285)	11.22 (285)
10.7 / 11.1 (17.2 / 17.9)	10.9 / 11.1 (17.6 / 17.9)	10.8 / 11.2 (17.4 / 18.1)
STD 112/120 (0.57/0.61)   TSU 106/114 (0.54/0.58)	STD 110/120 (0.56/0.61)   TSU 104/114 (0.53/0.58)	STD 106/120 (0.54/0.61)   TSU 100/114 (0.51/0.58)
STD 88/82 (0.45/0.42)   TSU 84/79 (0.43/0.40)	STD 88/82 (0.45/0.42)   TSU 84/79 (0.43/0.40)	STD 88/82 (0.45/0.42)   TSU 84/79 (0.43/0.40)
3359/2425 (14945/10787)	3375/2425 (15014/10787)	3390/2204 (15083/9807)
37.5 / 20.9	33.2 / 18.6	31.3 / 17.1
Drum	Drum	Drum
Yanmar 4TNV88	Yanmar 4TNV88	Yanmar 4TNV88
38.6 (28.8) @ 2400	38.6 (28.8) @ 2400	38.6 (28.8) @ 2400
2600	2600	2600
4 / 134 (2.2)	4 / 134 (2.2)	4 / 134 (2.2)
2030 (140)	2030 (140)	2030 (140)
81	81	81





## ***& Don't Forget...*** **Safety Starts With You!**

### **Before operating a lift truck, an operator must:**

- Be trained and authorized
- Read and understand operator's manual
- Not operate a faulty lift truck
- Not repair a lift truck unless trained and authorized
- Have the overhead guard and load backrest extension in place
- Perform daily inspections

### **During operation, a lift truck operator must:**

- Wear a seat belt
- Keep entire body inside truck cab
- Never carry passengers or lift people
- Keep truck away from people and obstructions
- Travel with lift mechanism as low as possible and tilted back
- Allow safe stopping distance and come to a complete stop before leaving operator compartment

### **To park a lift truck, an operator must:**

- Completely lower forks or attachments
- Shift into neutral
- Turn key off
- Set parking brake



- We don't just build forklifts. As a company, we are also focused on providing our customers with the best possible technical service support and aftermarket parts available.
- Even though our business starts with a quality, cost-effective product, our organization understands that it is the support and services we provide after the sale that help keep your business running at peak efficiency.
- **THE CLARK PartsPRO® SYSTEM** is our industry-leading electronic parts and service documentation tool that provides dealers with a quick and accurate method of identifying parts for every CLARK forklift built since 1961. PartsPRO® ensures the availability of the most current technical information and has the unique capability to create parts manuals specific to your mixed CLARK fleet, making it simple to positively identify and order the correct part(s) from your local CLARK dealer. The right CLARK part — The First Time, Every Time.
- **UNRIVALED PARTS SUPPORT** Our Aftermarket Distribution Center provides parts to over 250 North American CLARK dealers and many international dealers. This CLARK operated 184,000 square foot facility is dedicated to supporting the CLARK models built over the last 90 years. This facility is focused on providing excellent off-the-shelf availability, quality parts, quick response time and competitive pricing.

**DEPENDABLE PARTS = DEPENDABLE TRUCKS**

To Find Your Nearest Authorized CLARK Dealer, Visit Our Website [www.clarkmhc.com](http://www.clarkmhc.com)



**BUILT TO LAST.®**



**CLARK MATERIAL HANDLING COMPANY**

North American Headquarters  
700 Enterprise Drive • Lexington, KY 40510  
866-252-5275 • [www.clarkmhc.com](http://www.clarkmhc.com)

**C15/18/20sC & C15/18/20s**  
59-894-0423 Printed in USA CR03095M

© 2009 CLARK Material Handling Company